

EK450

18" WIDE BELT CONVEYOR

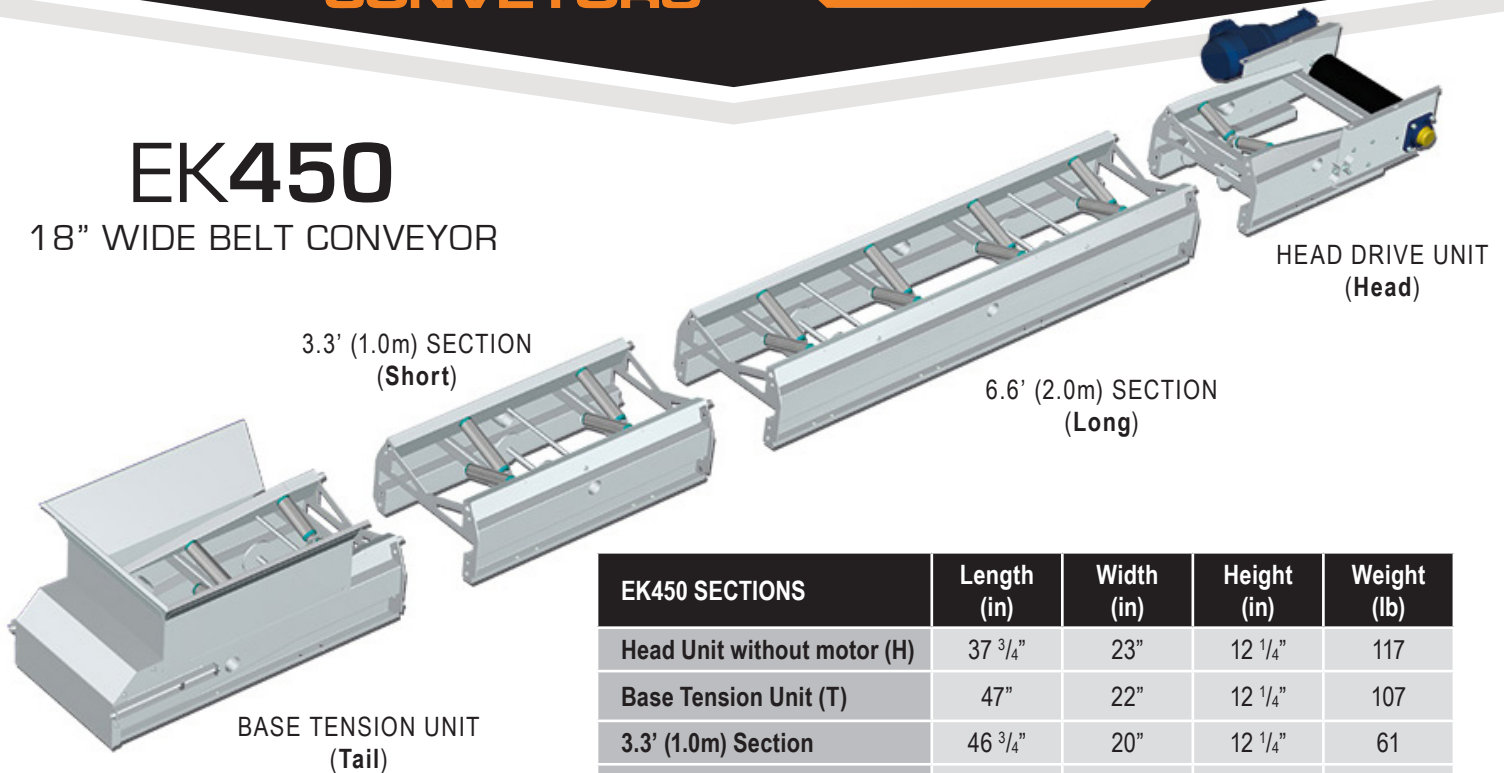

BASE TENSION UNIT
(Tail)

3.3' (1.0m) SECTION
(Short)

6.6' (2.0m) SECTION
(Long)

HEAD DRIVE UNIT
(Head)

High Performance Modular Conveyors

EASIKIT modular conveyor systems offer an adaptable solution for virtually any application, being assembled with standard components and built to project-specific requirements.

- Same-Day Quotations
- Fast Availability
- Supplied Ready-to-Assemble
- Adaptable Modular Design
- Bolted Joints
- Robust Construction
- Durable Galvanized Finish
- **Safe by Design**

Ideal for construction work, civil work, and bulk handling.

EK450 SECTIONS	Length (in)	Width (in)	Height (in)	Weight (lb)
Head Unit without motor (H)	37 3/4"	23"	12 1/4"	117
Base Tension Unit (T)	47"	22"	12 1/4"	107
3.3' (1.0m) Section	46 3/4"	20"	12 1/4"	61
6.6' (2.0m) Section	86"	20"	12 1/4"	113
Small Steel Hopper	32 1/2"	24 3/4"	12 1/2"	46

Length	Conveyor Section Combinations				Approx. Belt Length (ft)	Weight (lb)*
	Tail	Short	Long	Head		
7' (2m)	1	-	-	1	13' (4m)	375
10' (3m)	1	1	-	1	20' (6m)	463
13' (4m)	1	-	1	1	26' (8m)	540
16' (5m)	1	1	1	1	33' (10m)	628
20' (6m)	1	-	2	1	39' (10m)	706
23' (7m)	1	1	2	1	46' (14m)	794
26' (8m)	1	-	3	1	53' (16m)	871
30' (9m)	1	1	3	1	60' (18m)	959
33' (10m)	1	-	4	1	66' (20m)	1,036
36' (11m)	1	1	4	1	72' (20m)	1,125
39' (12m)	1	-	5	1	78' (24m)	1,202
43' (13m)	1	1	5	1	86' (26m)	1,290
46' (14m)	1	-	6	1	92' (28m)	1,356
49' (15m)	1	1	6	1	98' (30m)	1,444
53' (16m)	1	-	7	1	106' (30m)	1,521

LONGER COMBINATIONS AVAILABLE

*Weights provided include plain belt and motor.; Allow 3.3' (1m) extra belt for vulcanized belt joints; Maximum length of conveyor depends on application.

Construction. Folded mild steel sections forming parallel box side members with RHS cross-bracing, hot dip galvanized for durability. Simple joints with four locating spigots that are bolted together rigidly and all sections incorporate a scaffold support point.

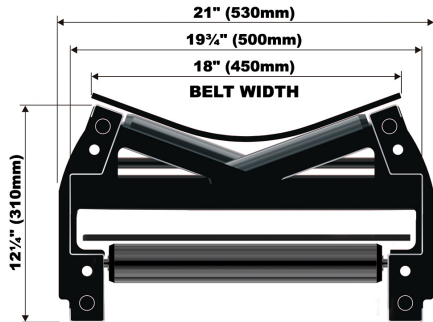

Idlers

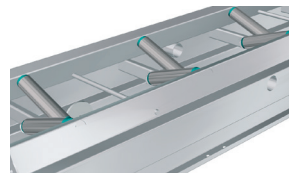

2" (50mm) diameter top rollers in pairs at 20" (500mm) centers forming 20° trough, bolted in slots to allow belt tracking adjustment.

Head Drive Unit



Incorporating 6.8" (173mm) diameter crowned diamond rubber lagged drive drum welded on to machined shaft with 1.37" (35mm) diameter keyed extension for attaching gearbox and motor. Mounted in self aligning bearings and complete with tracking adjustment.

Disc Return Rollers

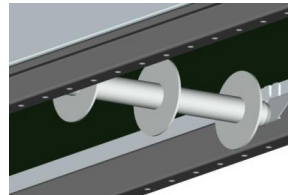

EASIKIT EK450 is supplied with Disc Return Rollers as standard. These help prevent material build up and are fitted at 40" (1,000mm) centers.

**Standard Return Rollers supplied if chevron belting is required.*

Intermediate Sections

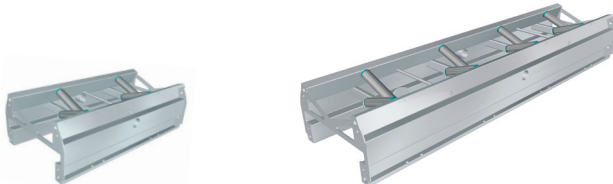

3.3' (1.0m) long

or

6.6' (2.0m) long

Belt Options

18" (450mm) wide 2-ply black rubber belts in the following styles:



a) **PLAIN** – for conveyors operating up to 20 degrees. Standard or Nitrile (oil resistant) for special applications.

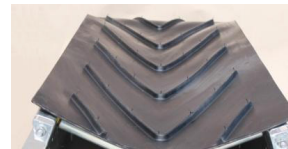

b) **CHEVRON** –for conveyors operating up to 35 degrees. Fitted with 1/2" (15mm) chevron pattern.



c) **CLEATED** –for conveyors operating up to 45 degrees. Fitted with 2" (50mm) high cleats at 20" (500mm) pitch for conveyors operating at steeper inclines.

Base Tension Unit

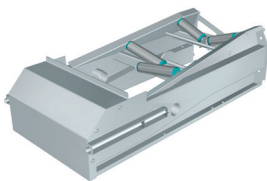

Complete with 6.5" (165mm) diameter crowned idler drum on fixed shaft with self-aligning bearings. Large amount of screw tension to allow easy fitting and removal of belt.