

SAFEBELT CONVEYORS

Self-Assembly Flat Economical Belt Conveyors. **SAFEBELT.**

Designed specifically with industrial applications in mind, the SAFE-Belt Conveyor delivers efficient unit handling wherever it's needed.

Whether you're looking for a temporary or permanent unit handling system, SAFE-Belt Conveyors are the premiere choice for:

- Logistics / Distribution Centers
- Factories
- Warehouses
- Airports

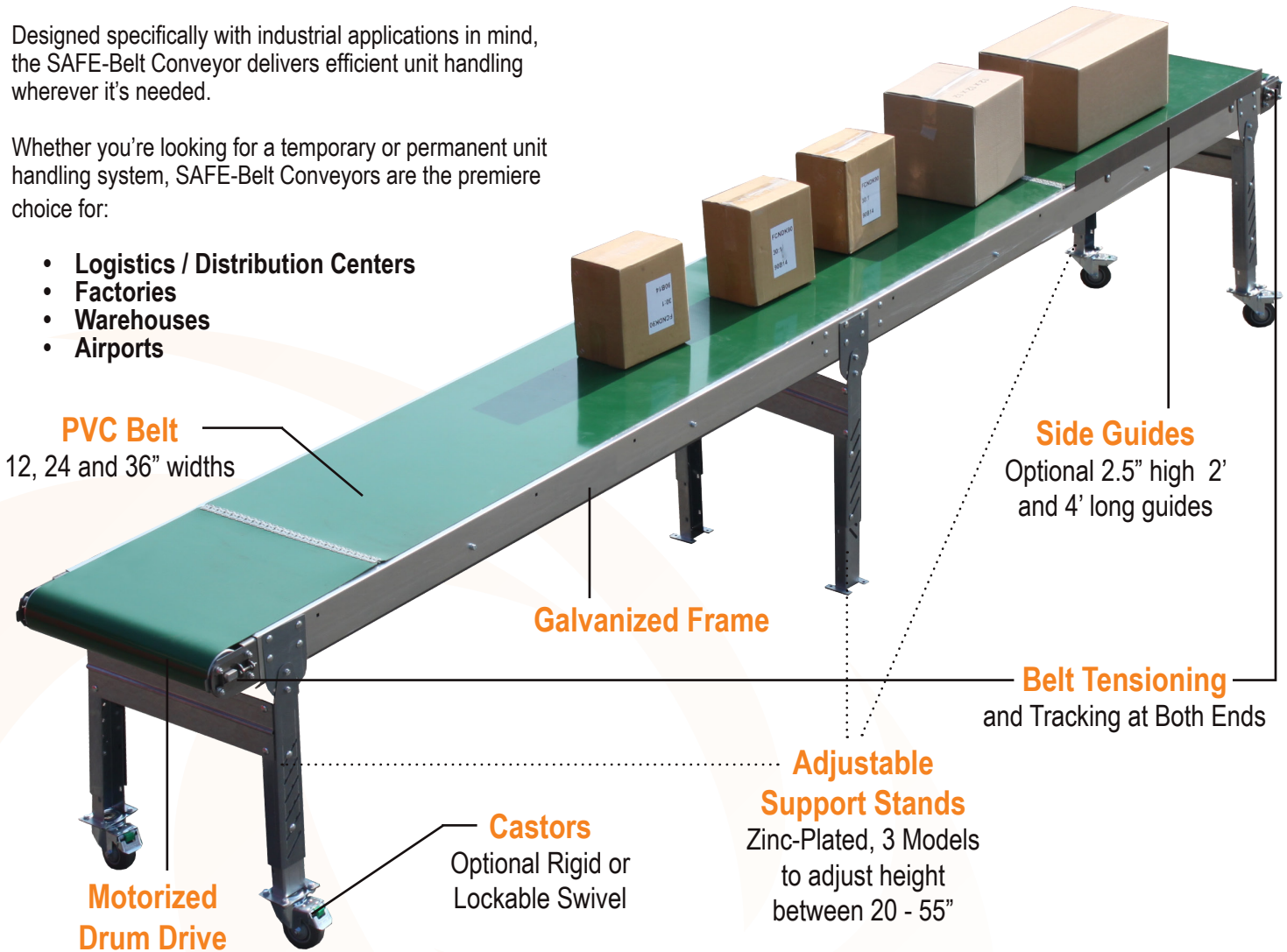

SB300

12" Belt
3' to 42' Long



SB600

24" Belt



SB900

36" Belt

INTERQUIP
CONVEYORS



(203) 322-2600



interquip.us/safebelt



info@interquip.net

Safe and Easy to Assemble and Reconfigure!

3 standard widths (12", 24" or 36") and over 20 standard lengths from 3' to 42' assembled from 2', 4' and 8' sections.

SAFE BELT CONVEYORS

SELF ASSEMBLY FLAT ECONOMICAL BELT CONVEYORS

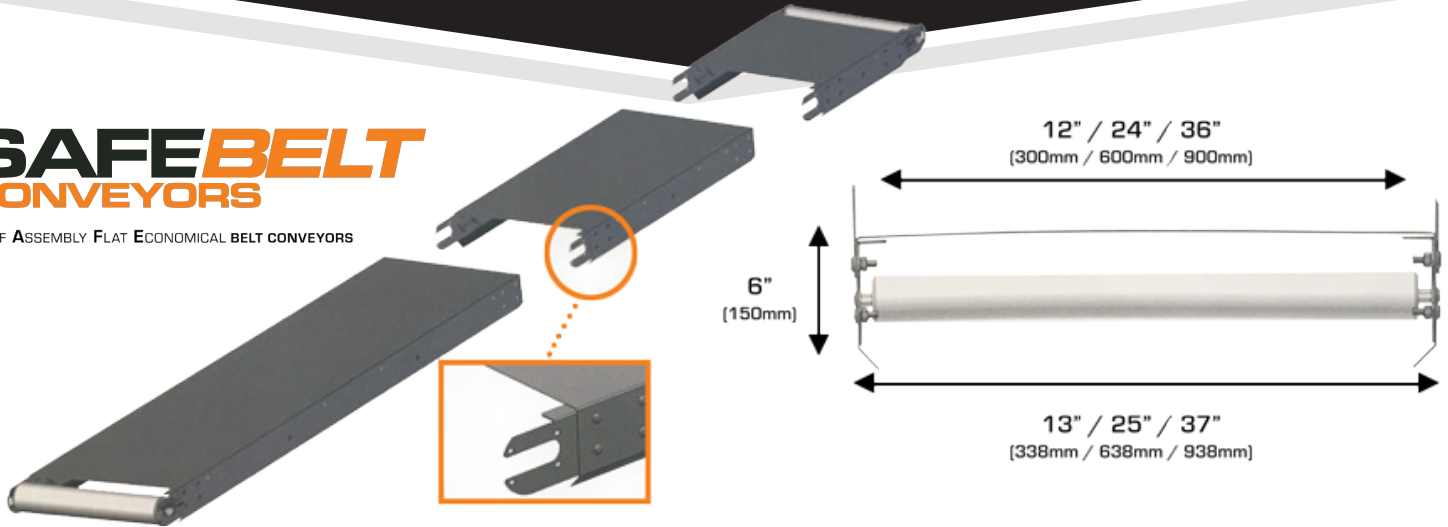

SPECIFICATIONS

Models	SB300 (12" Belt), or SB600 (24" Belt) or SB900 (36" Belt)			
Belt Speed	Variable Speed (1' - 3' per second)			
Approx. Length	SECTIONS REQUIRED			STANDS REQUIRED
	2'	4'	8'	
3'	1			2
5'		1		2
7'	1	1		2
9'			1	2
11'	1		1	2
13'		1	1	3
15'	1	1	1	3
17'			2	3
19'	1		2	3
21'		1	2	4
23'	1	1	2	4
25'			3	4
27'	1		3	4
29'		1	3	5
31'	1	1	3	5
32.5'			4	5
34.5'	1		4	5
36'		1	4	6
38'	1	1	4	6
40'			5	6
42'	1		5	6

STANDARD STAND HEIGHTS

- Stand 1 : 20" – 27"
- Stand 2 : 27" – 38"
- Stand 3 : 38" – 55"

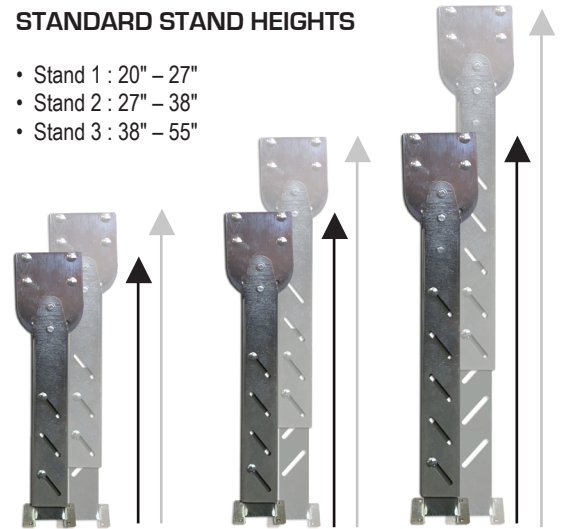

CASTORS

Optional 4" castors can be added to the stands to increase the mobility of your conveyor. Choice of rigid (straight rolling) or lockable swivel castors will add 5" to the overall conveyor height.



INTERQUIP CONVEYORS

(203) 322-2600

interquip.us/safebelt

info@interquip.net